

Visual Inspection

Semi-Auto Visual Inspection Equipment

This equipment is designed to perform visual inspection of Vials, Bottles, Ampoules & Syringes and Cartridges minimizing product/package handling.

VS 100 is suitable to handle a wide range of container types and sizes. Its max operating speed is 100 pieces per minute.

Using one VS 100 equipment one operator can reach the same productivity of 4-5 operators in a typical manual-inspection process.
Product capabilities: Liquid, Lyophilized, Powder and Empty Containers

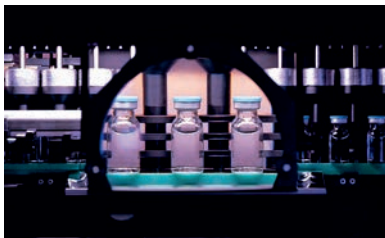

VS 100

INNOVATIVE SOLUTIONS IN PHARMACEUTICAL MANUFACTURING

Key Benefits

- Back light, front light and bottom light (Tyndall) configurable systems
- Modular infeed/outfeed systems for multiple containers
- Back to Back configuration, Dual hood/inline configuration
- Complete line integration: including accumulators, turntables and conveyors
- Rate, infeed, outfeed and reject counters
- Adjustable inclination of roller transport

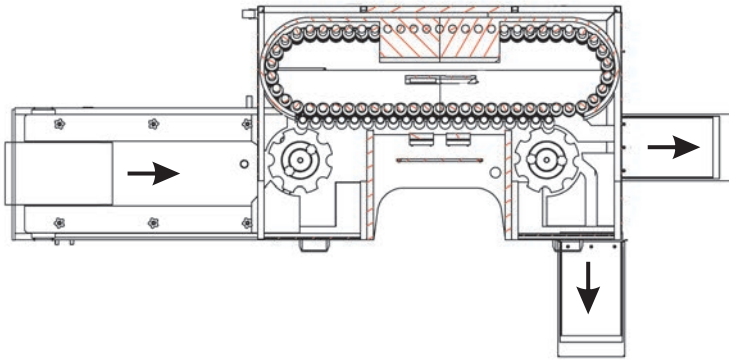

Relevant Features

- Suitable for inspection of vials, ampoules, cartridges syringes, bottles
- Wide range of container sizes: diameter [8-52]mm, height up to 100mm
- Automatic reject option: break beam curtain or push button type
- Reject classification: 4-6 categories
- High Quality Components: all parts used in VS 100 pass strict quality control tests, ensuring a long lifespan, even with 24/7 use
- Quick container size changeover
- Extremely Compact design with superior clean-ability & scratch resistance

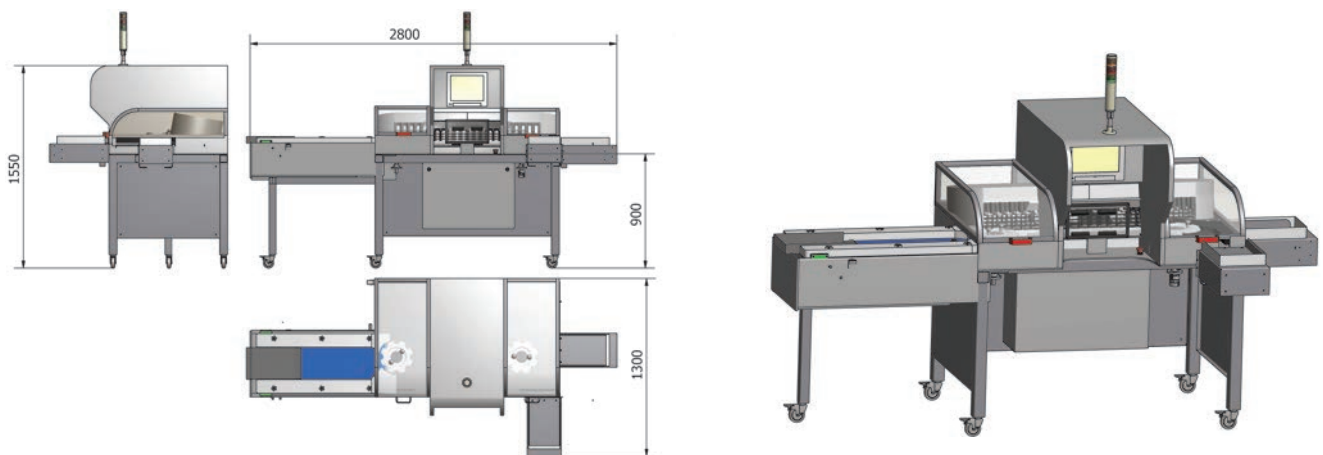

XEPICS SA

Via S. BALESTRA 27
6900 LUGANO (TI)
SWITZERLAND

www.xepics.com

Via BROGEDA, 3
69800 CHIASSO (TI)
SWITZERLAND

Tel: +41 (091) 6830839

info@xepics.com